

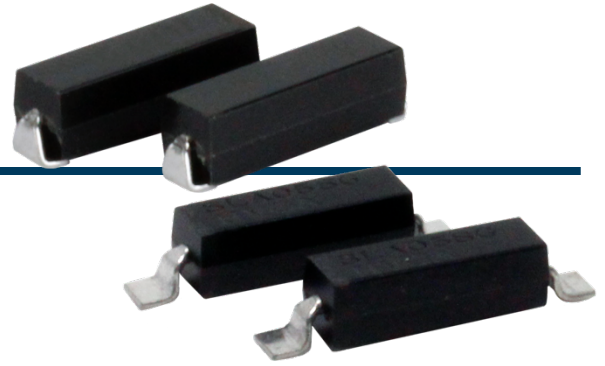

SLA-S SERIES

5 to 30kV, 40 to 130mA, 100nS
Surface Mount Diodes



Features

- Long Surface Mount Package
- J Lead or Gullwing Package Option
- Available in Cut Tape and 1000 Piece Reels
- Molded Plastic Body, ANSI/UL94 V-0 Rated Material

Specifications¹

Part Number	V _{RRM} V	I _{FAVM1} ² mA	I _{FAVM2} ² mA	I _{FAVM3} ² mA	V _F V	I _R μA	I _{FSM} A	C _J pF	T _{RR} nS	R _{θJL} °C/W	R _{θJC} °C/W
J Lead Subseries (Figure 1)											
SLA05S	5000	130	45	80	15.6	0.5	3	2.0	100	50	57
SLA06S	6000	125	40	75	18.8	0.5	3	1.6	100	50	57
SLA08S	8000	110	35	70	21.8	0.5	3	1.2	100	50	57
SLA10S	10000	95	30	55	25.2	0.5	3	1.1	100	50	57
SLA12S	12000	80	25	50	27.5	0.5	3	0.9	100	50	57
SLA15S	15000	70	25	48	35.0	0.5	3	0.9	100	50	57
SLA20S	20000	55	20	40	40.0	0.5	3	0.6	100	50	57
SLA25S	25000	50	18	32	45.0	0.5	3	0.5	100	50	57
SLA30S	30000	40	12	25	55.0	0.5	3	0.4	100	52	60
Gullwing Subseries (Figure 2)											
SLA05SG	5000	130	45	80	15.6	0.5	3	2.0	100	50	57
SLA06SG	6000	125	40	75	18.8	0.5	3	1.6	100	50	57
SLA08SG	8000	110	35	70	21.8	0.5	3	1.2	100	50	57
SLA10SG	10000	95	30	55	25.2	0.5	3	1.1	100	50	57
SLA12SG	12000	80	25	50	27.5	0.5	3	0.9	100	50	57
SLA15SG	15000	70	25	48	35.0	0.5	3	0.9	100	50	57
SLA20SG	20000	55	20	40	40.0	0.5	3	0.6	100	50	57
SLA25SG	25000	50	18	32	45.0	0.5	3	0.5	100	50	57
SLA30SG	30000	40	12	25	55.0	0.5	3	0.4	100	52	60

Temperature °C	
Storage Temperature	-55 to 175
Operating Temperature	-55 to 125
Maximum Junction Temperature	125

¹25°C ambient temperature unless stated otherwise.

²Check Specification Definitions for conditions details.



Drawings

Dimensions in inches [mm], tolerances ± 0.020 except as noted

Figure 1 – J Lead Subseries

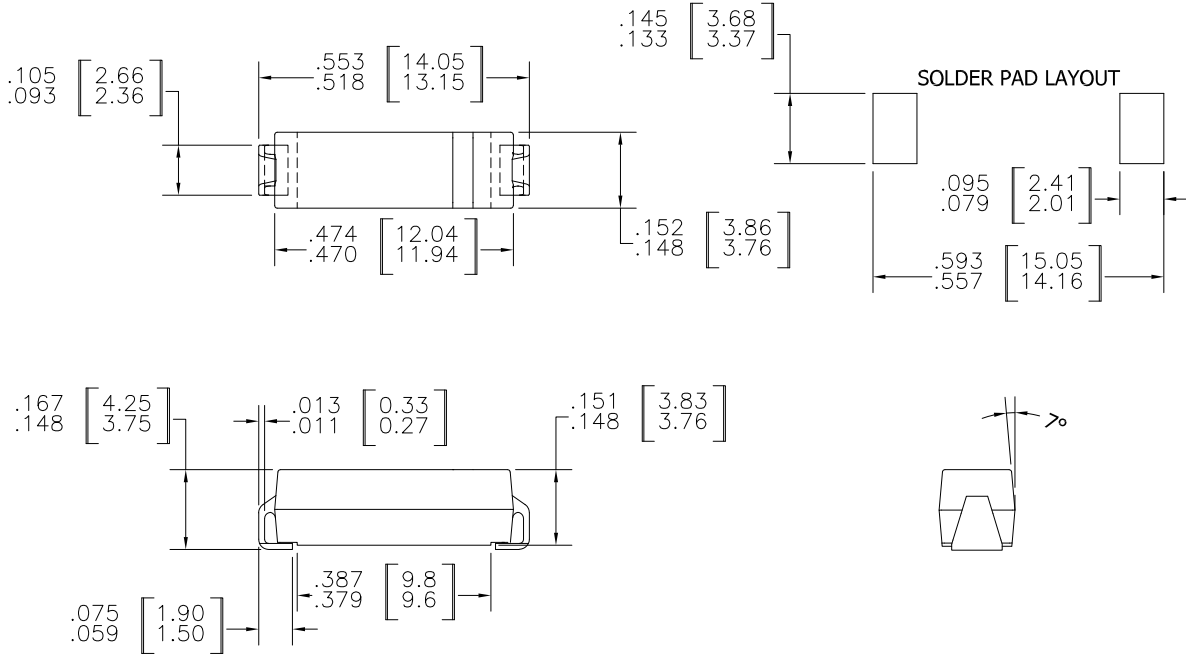
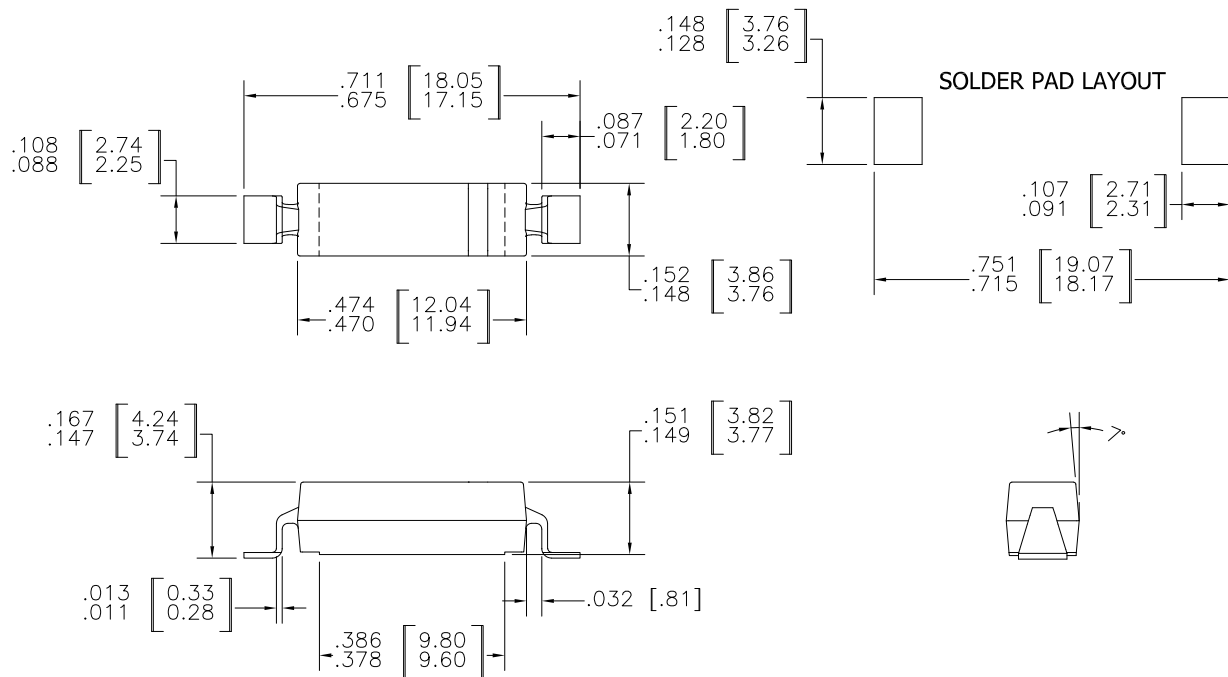
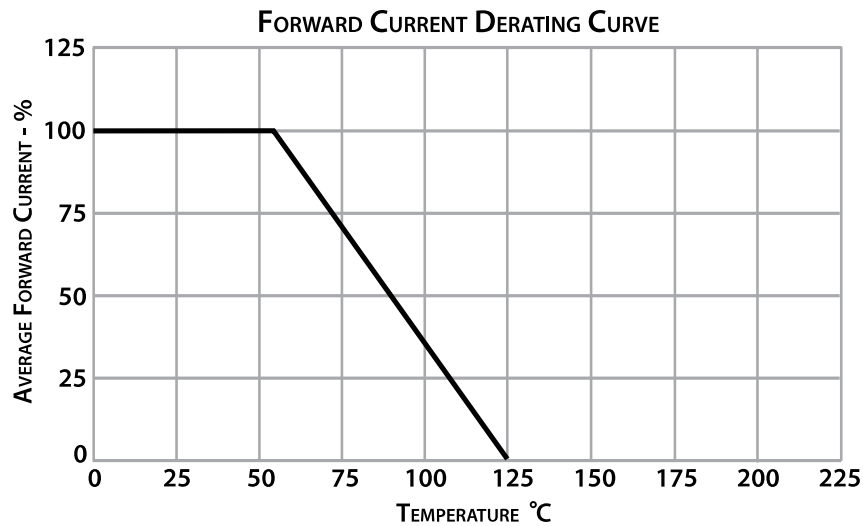
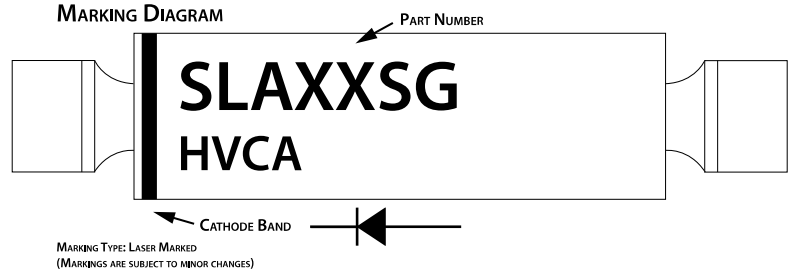
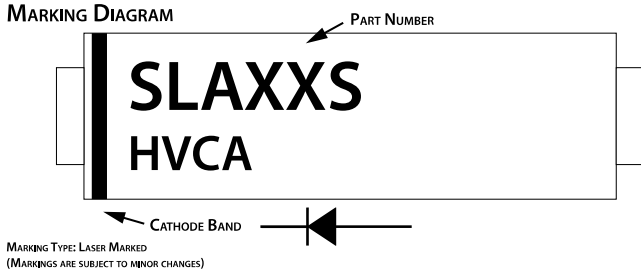

Figure 2 – Gullwing Subseries





Specification Definitions

Specifications		Conditions
V_{RRM}	Maximum Repetitive Reverse Voltage	-
I_{FAVM1}	Maximum Average Forward Current	At T _L = 55°C
I_{FAVM2}	Maximum Average Forward Current	At T _L = 100°C
I_{FAVM3}	Maximum Average Forward Current	At T _C = 70°C
V_F	Maximum Forward Voltage Drop	At I _{FAVM1}
I_R	Maximum Leakage Current	At V _{RRM}
I_{FSM}	Maximum Surge Current	At 8.3 mS, Single Half Sine
C_J	Typical Junction Capacitance	At V _R = 0VDC, f = 1MHz
T_{RR}	Maximum Reverse Recovery Time	I _F = 0.5 I _{FAVM1} ; I _R = -I _{FAVM1} ; I _{RR} = -0.25 I _{FAVM1}
R_{θJL}	Typical Thermal Resistance Junction to Lead	Device Mounted on 0.2" x 0.2" (5mm x 5mm) Copper Solder Pads
R_{θJC}	Typical Thermal Resistance Junction to Case	Device Mounted on 0.2" x 0.2" (5mm x 5mm) Copper Solder Pads



Note: Specifications subject to change without notice. Photo is representation only.