



High Voltage Products. High Voltage Experts.

Installation Instructions

Industrial Cable Assemblies

Safety Instructions	2
Standard Industrial Cable Assembly Data	3
Cleaning Instructions	4
Compression Gap	5
Grease Application	7
Fitting Instructions	8
Maintenance Schedule	10
Installation Grease	11

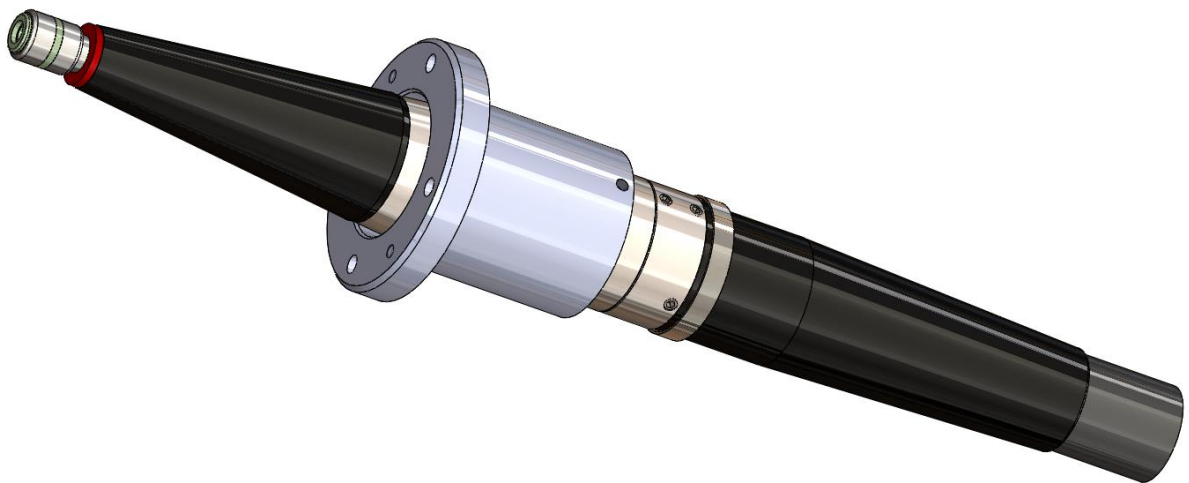



Industrial Cable Assemblies should only be fitted by a trained person following all instructions outlined in this booklet



Ensure power to HV generator is disconnected & secured against switch on



Cable can retain electrical charge or recharge itself – discharge tip contacts to ferrule (shield) / earth before handling



Ensure cleanliness at all times. Use lint free cloths, talc free gloves & isopropyl alcohol only



Do not apply solvent directly to plug / receptacle surfaces



Do not apply solvent directly to plug / receptacle surfaces



P00075/C installation grease should be applied to the termination



Support weight of cable during & after installation



Ensure that the termination is fully inserted in the socket before adjusting clamping flange



Do not install / operate system if temperature is below 15°C



Do not install / use any Industrial Cable Assembly with visible damage or defects



Only approved Essex X-Ray Receptacles & Accessories to be used

Standard Industrial Cable Assembly Data

CABLE DATA

	C2212	C2042	C2236
Rated Voltage	125kVdc	230kVdc	320kVdc
Impedance	53Ω	59Ω	61Ω
Capacitance	131pF/m	115pF/m	102pF/m
Minimum Bend Radius	101mm	152mm	190mm
Minimum Ambient Temperature	-51°C	-51°C	-51°C
Maximum Conductor Temperature	121°C	121°C	121°C
Weight	0.49kg/m	1.07kg/m	1.63kg/m
Outer Diameter	19.9mm	31.1mm	38.2mm

CONNECTOR OVERVIEW

	R10	R10 SL	R10 RA	R10 SL R/A	R24	R24 SL	R24 R/A	R24 SL R/A
C2212	100kV	100kV	100kV	100kV	100kV	100kV	-	-
C2042	-	-	-	-	160-225kV	160-225kV	160-225kV	160-225kV
C2236	-	-	-	-	225kV	225kV	225kV	225kV

	R28	R28 SL	R28 SL	R28 SL R/A	R30	R30 SL	R30 R/A	R30 SL R/A
C2212	-	-	-	-	-	-	-	-
C2042	225kV	225kV	225kV	225kV	230kV	-	230kV	-
C2236	225kV	225kV	225kV	225kV	300kV	300kV	300kV	300kV

CLAMPING SLEEVES

Part Number	Description	Length	Thread
SK1328/A	R10 Short Small PCD	53mm	M32 x 1.5mm
SK1328/B	R10 Short Large PCD	53mm	M32 x 1.5mm
T20051/A	R10 Straight Small PCD	80mm	-
T20052	R10 Straight Large PCD	85mm	-
T20785/A	R10 Right Angle Small PCD	25mm	M48 x 1.5mm
T20785/B	R10 Right Angle Large PCD	25mm	M48 x 1.5mm
T20844	R24 Short	70mm	M45 x 1.5mm
T22752	R24 Short 'L' Cable	76mm	M56 x 1.5mm
T20131/A	R24 C/Sleeve	102mm	M45 x 1.5mm
T20697	R24 c/w Cut Outs	102mm	M45 x 1.5mm
T20045/F	R24 6-Hole	100mm	M45 x 1.5mm
T20697/A	R24 R/A c/w Cut Outs	87mm	M45 x 1.5mm
T22179	R24 Sprung	70mm	M45 x 1.5mm
T22813	R24 Windowed	102mm	M45 x 1.5mm
T22717	R28 Short	73mm	M56 x 1.5mm
T20289	R28 C/Sleeve	118mm	M56 x 1.5mm
T20405	R28 R/A	105mm	M56 x 1.5mm
T22182	R28 Sprung	104mm	M56 x 1.5mm
T20172/A	R30 C/Sleeve	110mm	M62 x 1.5mm
T22185	R30 Sprung	104mm	M62 x 1.5mm

SPRING LOADED CONNECTORS

SPRING LOADED



SOLID

- Spring loaded connectors have a mechanical spring built into the ferrule
- The tension of a sprung termination creates constant pressure in the receptacle
- Simple to install a tight, secure connection with lower maintenance costs
- Eliminates over-gapping and the need for re-gapping
- Features compression rings as a visual aid during installation and maintenance
- Increases service life of cable and tube
- Compatible 'short' and 'windowed' clamping sleeves allow for compression ring viewing

HOW TO ORDER

	Cable Type	Connector	Connector	Length
Cable Assembly*	C2042	R24 SL	R28 SL	5m
Clamping Sleeves	T20844 & T22717			

*Example R24 – R28 spring-loaded cable assembly with straight connectors

Please refer to the safety instructions on page 2 of this booklet at all stages of the installation process

STEP 1

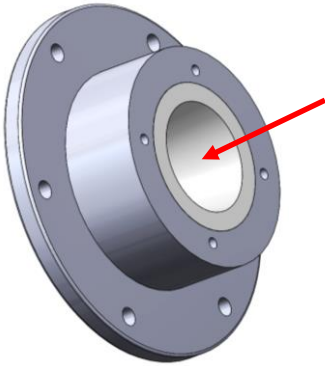

- 1) Clean contacts at bottom of Receptacle cone using a long foam bud with IPA
- 2) Clean internal cone of Receptacle with IPA, using lint free wipes (wrap around a tool or bottle brush)

Note: Take care not to scratch surface. Ensure no particles/grease are left on surface

STEP 2

- 1) Ensure two grub screws in Clamping Sleeve are clear of internal bore
- 2) Check Clamping Sleeve is clean particularly internal surfaces/thread

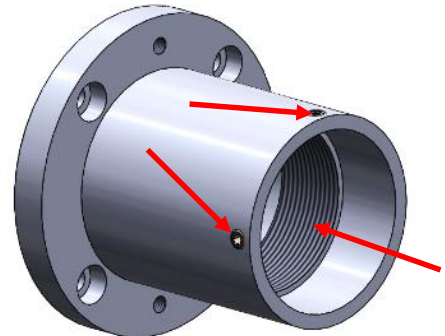

STEP 3



- 1) Screw Clamping Sleeve onto cable plug, until it passes front end of ferrule
- 2) Clean internal cone of Receptacle with IPA, using lint free wipes (wrap around a tool or bottle brush)
- 3) Clean contact tips at tip of Plug

Note: Ensure no particles/grease are left on surface

Please refer to the safety instructions on page 2 of this booklet at all stages of the installation process

COMPRESSION GAP TABLE

	R10 Solid	R10 SL	R24 Solid	R24 SL	R28 Solid	R28 SL	R30 Solid	R30 SL
Compression Gap	4mm	7mm	6mm	7mm	6mm	7mm	6mm	9mm

Note: 'SL' denotes a spring-loaded connector/plug

STEP 1

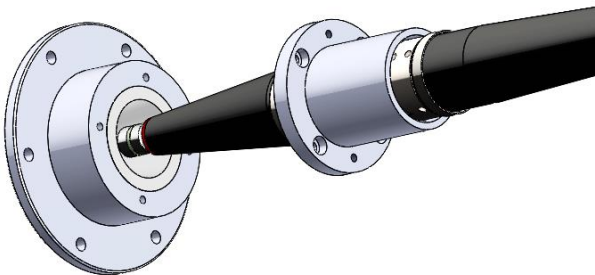

- 1) Insert Plug into Receptacle
- 2) Ensure plug tip has connected fully into socket by feeling for some resistance during the last 20mm of insertion

STEP 2

- 1) Select appropriate compression gap from above table. Use a suitable gauge if available
- 2) Screw Clamping Sleeve away from Receptacle so that compression gap gauge will slide between Receptacle & Clamping Sleeve with some clearance

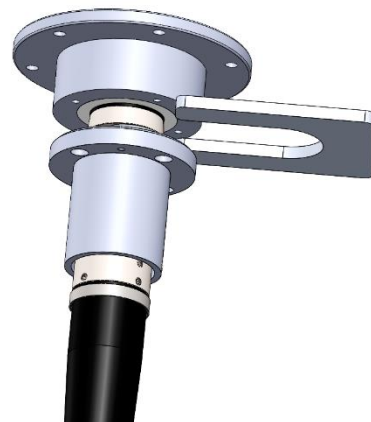

Please refer to the safety instructions on page 2 of this booklet at all stages of the installation process

COMPRESSION GAP TABLE

	R10 Solid	R10 SL	R24 Solid	R24 SL	R28 Solid	R28 SL	R30 Solid	R30 SL
Compression Gap	4mm	7mm	6mm	7mm	6mm	7mm	6mm	9mm

Note: 'SL' denotes a spring-loaded connector/plug

STEP 3

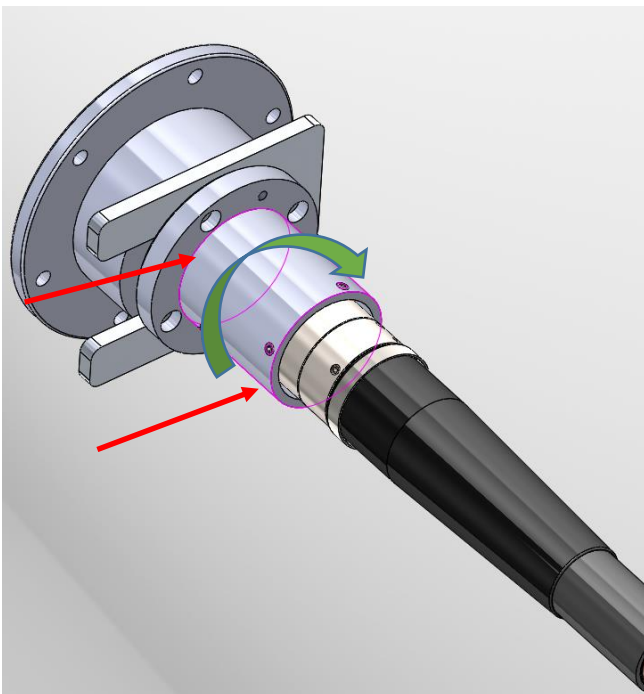

- 1) With the plug fully inserted into the Receptacle, screw Clamping Sleeve on to Plug ferrule so that it mates with face of gapping gauge. Maintain constant pressure on cable/plug
- 2) Remove compression gap gauge
- 3) Align holes of Clamping Sleeve with threaded holes in Receptacle flange
- 4) Set Clamping Sleeve initial position by lightly tightening grub screws in Clamping Sleeve against ferrule
- 5) Remove plug from receptacle

Please refer to the safety instructions on page 2 of this booklet at all stages of the installation process

GREASE APPLICATION TABLE

	R10 Solid	R10 SL	R24 Solid	R24 SL	R28 Solid	R28 SL	R30 Solid	R30 SL
Volume of Grease	1ml	1ml	2.5ml	2.5ml	2.5ml	2.5ml	5ml	5ml

Note: 'SL' denotes a spring-loaded connector/plug

STEP 1

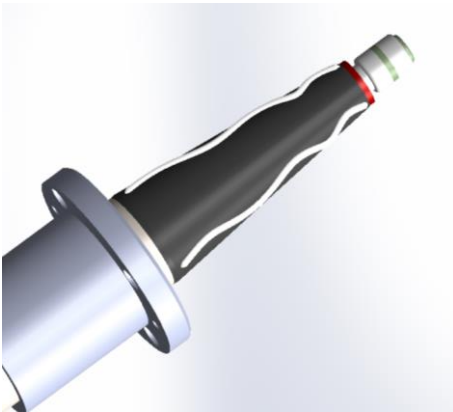

- 1) Check Plug & Receptacle mating surfaces are clean & free from particles/fibre
- 2) Apply appropriate volume of P00075/C Installation Grease in 3 or 4 beads, as per the above table

Note: Allow any cleaning solvent to evaporate before applying grease

STEP 2

- 1) Spread grease in a rotating motion to evenly cover the entire rubber cone

*Note: Wear fresh clean rubber gloves. **Do not get any grease on connection tip***

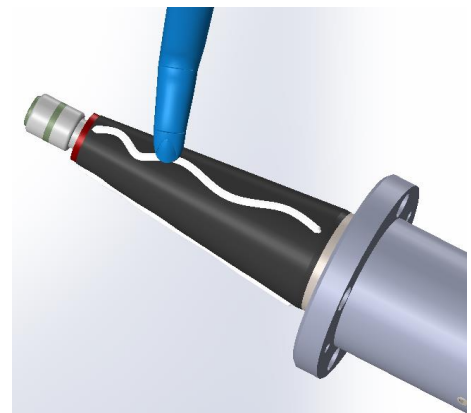

Please refer to the safety instructions on page 2 of this booklet at all stages of the installation process

STEP 1

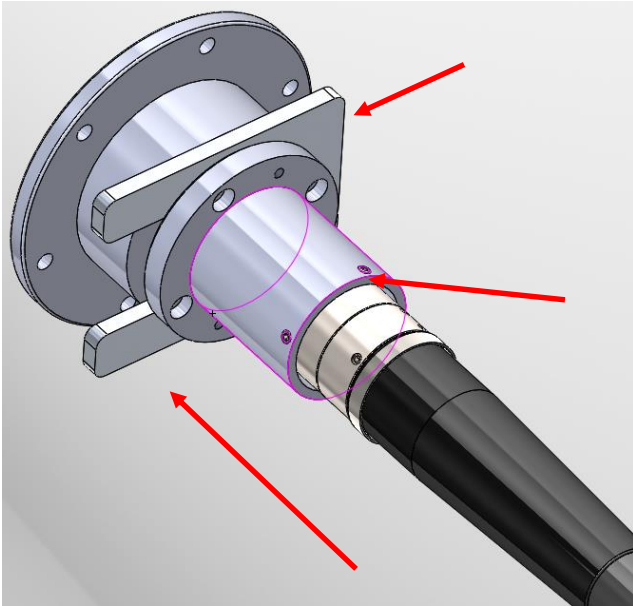

- 1) Fully re-insert plug into Receptacle taking care not to remove any grease from rubber cone
- 2) Apply firm pressure on cable plug and check compression gap.
- 3) Remove compression gap gauge
- 4) Align holes of Clamping Sleeve with threaded holes in Receptacle flange (only rotate anti-clockwise)
- 5) Set Clamping Sleeve position by tightening the grub screws

Note: If adjustment is required at stage 2, loosen grub screws in Clamping Sleeve & rotate so that it just touches face of gapping gauge

STEP 2

- 1) Twist plug in receptacle a few times to spread grease
- 2) Tighten down Clamping Sleeve using correct length screws (M5x20)
- 3) Tighten all screws gradually in sequence until Clamping Sleeve is mated against Receptacle flange with no gaps
- 4) Wait for 5 minutes

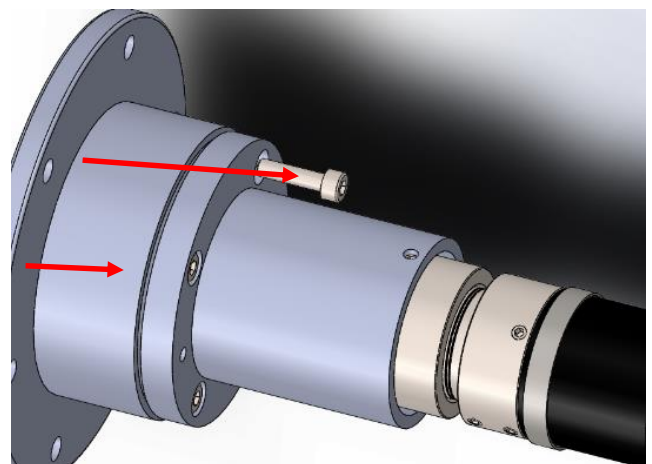

Note: Screws will become harder to turn as the rubber is compressed into Receptacle

Please refer to the safety instructions on page 2 of this booklet at all stages of the installation process

STEP 3

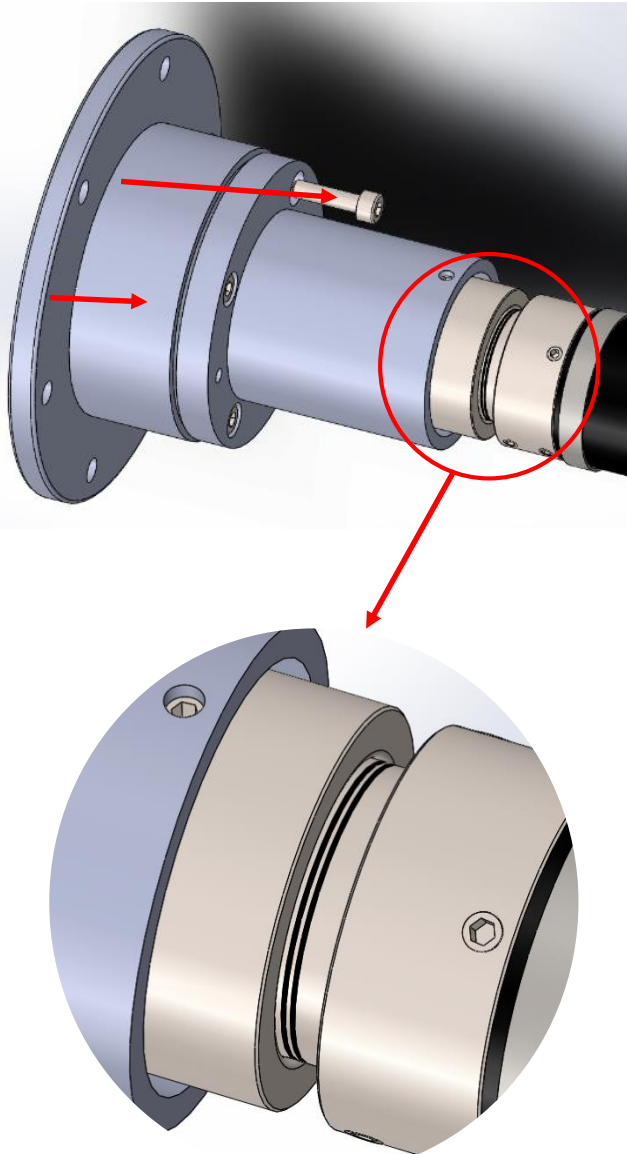

- 1) Undo screws but keep firm pressure on cable/plug
- 2) Re-check compression gap with gauge
- 3) If re-adjustment is required undo the two grub screws and follow steps 1 & 2
- 4) Tighten the two grub screws and re-fit the four screws to compress the Clamping Sleeve into the Receptacle

Note: Spring-loaded plugs feature compression rings as a visual aid during installation. Correct compression is indicated by two rings becoming visible when installed with a compatible short or windowed flange.

One compression ring visible = under compression

Three compression rings visible = over compression

Please refer to the safety instructions on page 2 of this booklet at all stages of the installation process

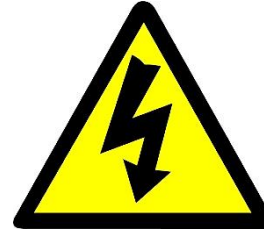

**DO NOT OPERATE SYSTEM UNTIL 2 HOURS AFTER
COMPRESSION/INSTALLATION**

**CHECK COMPRESSION GAP AFTER 1 WEEK – ADJUST IF REQUIRED
FOLLOWING THE INSTRUCTIONS OUTLINED IN THIS BOOKLET**

RECOMMENDED MAINTENANCE SCHEDULE

Plug Type	Maintenance Period
Solid Plug	6 months
Spring-Loaded Plug	1 year

P00075/C

DC4 Installation Grease



Trade Name	Dow Corning 4 Electrical Insulating Compound	
Appearance	Translucent White Inorganic Grease	
CAS#	Weight (%)	Component Name
68037-74-1	70.0 – 90.0	Dimethyl, methyl silicone resin
7631-86-9	7.0 – 13.0	Silica, amorphous
70131-67-8	5.0 – 10.0	Dimethyl siloxane, hydroxyl-terminated
Evaporation	30 hours/200°C max = 2.0%	
Service Temperature	-55°C to +200°C	
Relative Density	1.0g/ml at 25°C	
Dielectric Strength	1.27mm gap – 1.0kV/ml	
Permittivity	3.1 at 100Hz	3.1 at 100kHz
Dissipation Factor	0.0025 at 100Hz	0.0025 at 100kHz
Volume Resistivity	0.10 x 10 ¹⁵ Ohm/cm at 23°C	
Arc Resistance	120 seconds	

OVERVIEW

Dow Corning 4 (DC4) Electrical Insulating compound is a lubricating, grease like material used as a moisture proof seal for electrical assemblies and terminals. Used for cable connectors, battery terminals, switches and various other plastic on metal combinations.

FEATURES

- High dielectric strength
- Low volatility
- Moisture resistant
- Good thermal oxidation and chemical stability
- Retains its grease like consistency from -55°C to +200°C
- Odourless
- Highly water repellent
- Adheres readily to dry metals, ceramics, rubber, plastics and insulating resins

HOW TO USE

DC4 compound can be applied by hand using suitable PPE, dispensing equipment, brushing or wiping. A thinner consistency can be achieved by dispersing in solvents such as xylene, mineral spirits and methyl ethyl ketone. Compound can then be applied by brushing, dipping or spraying. DC4 should not be applied to any surface which will be painted or finished.

Note: Please refer to the manufacturers product safety data sheet for full product safety instructions



HVP
High Voltage Products. High Voltage Experts.

