



# SPS Series

250 – 6,000 Volt, 4 – 30 Watt  
Digital High Voltage Power Supply

## FEATURES

- Digital or Analog Remote Control
- Voltage and Current Monitoring
- Over Current and Over Voltage Protection
- Software Configurable Features and Performance
- Serial Communications with SDK
- Available GPIO Pins
- Data logging of Power Supply Parameters
- User Programmable Fault Handling



The SPS Series are high voltage power supplies utilizing a fully digital control loop. This patented technology enables the products to provide unprecedented flexibility in performance, features, and system integration. Both performance and features can be configured and customized through software. They offer remote monitoring and control, constantly log essential statistics while running for use in design or troubleshooting and are expandable through available GPIO pins. A Windows application and full development SDK are available to further enable design work, making the SPS series the fastest way to design with high voltage.

## SPECIFICATIONS

	Conditions	Value			Units
		4W	20W	30W	
<b>Input</b>					
<b>Voltage Range</b>	Full Power	+23 to 31	+23 to 31	+23 to 31	VDC
<b>Voltage Range</b>	Derated Power	+12 to 32	+12 to 32	+12 to 32	VDC
<b>Current</b>	Standby / Disable	< 60	< 60	< 60	mA
<b>Current</b>	No Load, Max Vout	< 175	< 175	< 175	mA
<b>Current</b>	Max Load, Max Vout	< 385	< 1,180	< 1,650	mA
<b>AC Ripple Current</b>	Nominal Input, Full Load	< 90	< 120	< 140	mA PP
<b>Output</b>					
<b>Dynamic Load Regulation</b>	½ to Full Load, Max Vout per 0.1 mA	1			V pk
<b>Line Regulation</b>	Nom. Input, Max Vout, Full Power	< 0.01			% VDC
<b>Static Load Regulation</b>	No Load to Full Load, Max Vout	< 0.08			% VDC
<b>Stability</b>	30 Min. Warmup, per 8 hr / per day	< 0.01 / < 0.02			% VDC
<b>Analog Controls and Monitoring</b>					
<b>Input Impedance</b>	Nominal Input	1.0 MΩ to SIGGND			MΩ
<b>Adjust Resistance</b>	Typical Potentiometer Values	100			kΩ
<b>Adjust Logic</b>	0 to +5 V (Option "-5**")	+4.5 VDC for Max Output			
	0 to +10 V (Option "-10**")	+9 VDC for Max Output			
<b>Reference Voltage</b>	At +25 °C (Option "-5**")	+5.00 VDC ±0.5%, Zout = 499Ω ±1%			
	At +25 °C (Option "-10**")	+10.00 VDC ±0.5%, Zout = 1000Ω ±1%			
<b>HV Output Enable / Disable</b>	Default HV Enabled (Option "L**")	0 to +1.5 Enable, +2.5 to 32 Disable			VDC
	Default HV Disabled (Option "H**")	0 to +1.5 Disable, +2.5 to 32 Enable			VDC
<b>Environmental</b>					
<b>Operating Temperature</b>	Ambient - Full Load, Max Vout	-40 to +60			°C
<b>Operating Temperature</b>	Case Temp - Full Load, Max Vout	-40 to +80			°C
<b>Temperature Coefficient</b>	Over the Operating Temperature	±50			PPM/°C
<b>Storage Temperature</b>	Non-operating, Case Temp.	-55 to +105			°C
<b>Humidity</b>	Non-condensing	0 to 95			%
<b>Altitude</b>	Standard Package, All Conditions	Sea Level to Vacuum			-

**MODELS\***

Model Number	Output Voltage	Output Current	Low Freq. <sup>1</sup> Ripple	High Freq. <sup>2</sup> Ripple	Output Capacitance	Arc Limiting Resistance	I <sub>MON</sub> Scaling <sup>3, 4</sup>	V <sub>MON</sub> Scaling <sup>3</sup>
<b>4 W Models</b>								
SPS-24-250●-4	25 to 250 V	16 mA	0.145	0.015	1 μF	22 Ω	12.0 mA / V	25 V/V
SPS-24-500●-4	25 to 500 V	8 mA	0.130	0.008	0.5 μF	56 Ω	6.0 mA / V	50 V/V
SPS-24-1000●-4	50 to 1,000 V	4 mA	0.060	0.060	0.33 μF	200 Ω	3.0 mA / V	100 V/V
SPS-24-2000●-4	25 to 2,000 V	2 mA	0.050	0.080	0.0068 μF	1,000 Ω	1.5 mA / V	200 V/V
SPS-24-4000●-4	25 to 4,000 V	1 mA	0.025	0.008	0.0034 μF	2,700 Ω	0.75 mA / V	400 V/V
SPS-24-6000●-4	25 to 6,000 V	0.67 mA	0.015	0.010	0.0023 μF	5,600 Ω	0.5 mA / V	600 V/V
<b>20 W Models</b>								
SPS-24-250●-20	25 to 250 V	80 mA	0.140	0.016	1 μF	22 Ω	12.0 mA / V	25 V/V
SPS-24-500●-20	25 to 500 V	40 mA	0.120	0.012	0.5 μF	56 Ω	6.0 mA / V	50 V/V
SPS-24-1000●-20	50 to 1,000 V	20 mA	0.110	0.007	0.33 μF	200 Ω	3.0 mA / V	100 V/V
SPS-24-2000●-20	25 to 2,000 V	10 mA	0.100	0.010	0.0068 μF	1,000 Ω	1.5 mA / V	200 V/V
SPS-24-4000●-20	25 to 4,000 V	5 mA	0.090	0.014	0.0034 μF	2,700 Ω	0.75 mA / V	400 V/V
SPS-24-6000●-20	25 to 6,000 V	3.3 mA	0.076	0.019	0.0023 μF	5,600 Ω	0.5 mA / V	600 V/V
<b>30 W Models</b>								
SPS-24-250●-30	25 to 250 V	120 mA	0.240	0.024	1 μF	22 Ω	12.0 mA / V	25 V/V
SPS-24-500●-30	25 to 500 V	60 mA	0.200	0.014	0.5 μF	56 Ω	6.0 mA / V	50 V/V
SPS-24-1000●-30	50 to 1,000 V	30 mA	0.156	0.012	0.33 μF	200 Ω	3.0 mA / V	100 V/V
SPS-24-2000●-30	25 to 2,000 V	15 mA	0.112	0.012	0.0068 μF	1,000 Ω	1.5 mA / V	200 V/V
SPS-24-4000●-30	25 to 4,000 V	7.5 mA	0.088	0.013	0.0034 μF	2,700 Ω	0.75 mA / V	400 V/V
SPS-24-6000●-30	25 to 6,000 V	5 mA	0.076	0.020	0.0023 μF	5,600 Ω	0.5 mA / V	600 V/V

\* Refer to below table for hardware option details. ● Substitute P or N for positive or negative output.

<sup>1</sup> % Vp-p 1 Hz to 1 kHz. <sup>2</sup> % Vp-p 1 kHz to 1 MHz. <sup>3</sup> Full scale signal, values listed are for -10 option, double for -5 option.

<sup>4</sup> I<sub>MON</sub> for -10 option, at maximum output current will read 1.33 V on 4 W models, 6.67 V on 20 W models, and 10.0 V on 30 W models. Half for 5 V reference options.

**HARDWARE OPTIONS**

**Standard Options (Choose 1)**

Append to Part #	Option
-5L	5 Volt Reference, Default HV Enable
-5H	5 Volt Reference, Default HV Disable
-10L	10 Volt Reference, Default HV Enable
-10H	10 Volt Reference, Default HV Disable

**Additional Options**

Append to Part #	Option	Incompatible With
-W	Flying High Voltage Lead (Approx. 18")	
-M	Mu-Metal Shielding Over Case	
-E	Eared Mounting Plate	-H
-H	Heatsink	-E

**MECHANICAL / DIMENSIONS**

Mechanical Specifications		
Volume	10.5 in <sup>3</sup>	172 cm <sup>3</sup>
Weight	10.4 oz	295 g
Case	DAP case certified to ASTM-D-5948	
Pins	0.100" Spacing	

Tolerances	
Overall	0.050" [±1.27 mm]
Pin to Pin	0.015" [±0.38 mm]
Mounting	0.025" [±0.64 mm]

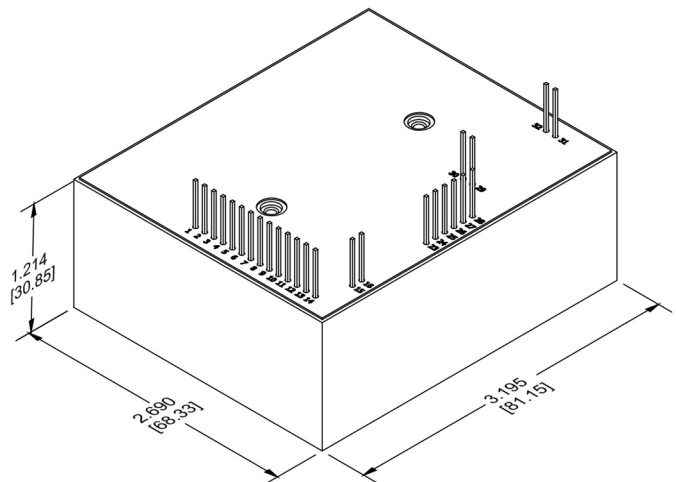

**ACCESSORY LIST**

Accessory	Part Number	Description
USB Cable	SPS-USB-Cable	Standard USB-A Male Cable with pin connector for connecting to SPS power supply.
USB Isolator	SPS-USB-Isolator	Provides isolation between USB host and peripheral, helping to protect PC when connected to SPS power supply.

**SOFTWARE AND CONFIGURATION OPTIONS**

A Windows GUI application designed to aid in development using the SPS Series, and a full Software Development Kit (SDK) with essential libraries and documentation are available at [www.deantechnology.com](http://www.deantechnology.com).

For a list of configuration options and default values see the SPS User Settable Parameters document. Virtually limitless configuration options as well as performance and feature customizations are possible through software changes. Contact the factory or authorized sales partner to discuss specific needs.

**PINOUTS\*\***

Pin	Name	Description	Min	Max
1	+VIN	Positive Power Input	12.5V	32V
2	-VIN	Power Ground Return	-	-
3	VREF	Reference Output	5 or 10V	5 or 10V   10mA
4	IMON	Current Monitor	-	-
5	ENABLE	Enable Input (>2.5V)	-	-
6	SIGGND	Signal Ground	-	-
7	VADJ	Analog Voltage Adjust Input	0V	5 or 10V
8	+5V	General Purpose +5V	5V	5V   100mA
9	GPIO0	GPIO (Default: 1s Pulse)	0V	3.3V   3.3mA
10	GPIO1	GPIO (Default: High if HV Enabled)	0V	3.3V   3.3mA
11	GPIO2	GPIO (Default: High if in Fault)	0V	3.3V   3.3mA
12	GPIO3	GPIO	0V	3.3V   3.3mA
13	IADJ	Analog Current Adjust Input	0V	5V or 10V
14	SIGGND	Signal Ground	-	-
15	GPIO4	GPIO	0V	3.3V   3.3mA
16	GPIO5	GPIO	0V	3.3V   3.3mA
23	-	Reserved for Factory	-	-
24	RXD	UART link	0V	3.3V
25	TXD	UART link	0V	3.3V
26	-	Reserved for Factory	-	-
27	-	Reserved for Factory	-	-
28	GND	Ground	-	-
29	VMON	Voltage Output Monitor	-	5 or 10V
30	HVRTN	High Voltage Ground Return	-	-
31	HVOUT1	HV Output	-	-
32	HVOUT2	HV Output	-	-

\*\* Total Current Output of All GPIO is 20 mA

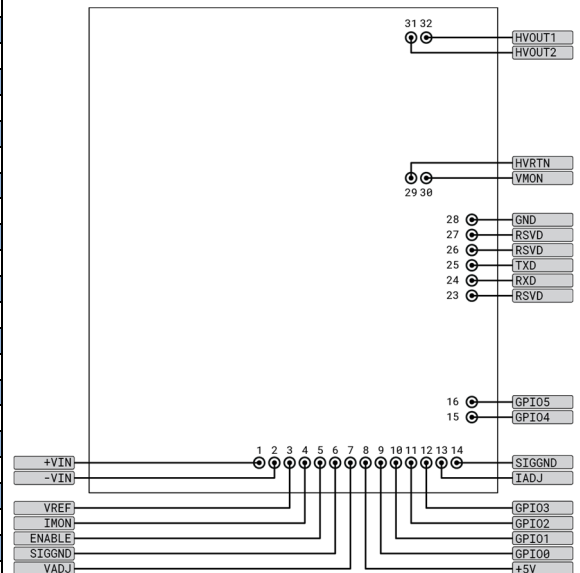

**CERTIFICATIONS**



**PATENTS**

Protected by US and foreign patents  
[www.deantechnology.com/patents](http://www.deantechnology.com/patents)